

N-Channel Dual Gate MOS-Fieldeffect Tetrode, Depletion Mode

Electrostatic sensitive device.
Observe precautions for handling.



Applications

Input- and mixerstages especially for UHF-tuners.

Features

- Integrated gate protection diodes
- High cross modulation performance
- Low noise figure
- High AGC-range
- Low feedback capacitance
- Low input capacitance

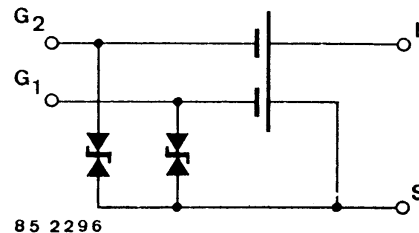
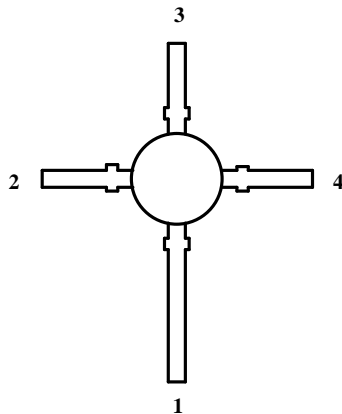

BF961 Marking
Plastic case (~TO 50)
1 = Drain, 2 = Source, 3 = Gate 1, 4 = Gate 2

BF961 Marking
Plastic case (~TO 50)
1 = Drain, 2 = Source, 3 = Gate 1, 4 = Gate 2

Absolute Maximum Ratings

Parameters	Symbol	Value	Unit
Drain source voltage	V_{DS}	20	V
Drain current	I_D	30	mA
Gate 1/Gate 2-source peak current	$\pm I_{G1/2SM}$	10	mA
Total power dissipation $T_{amb} = 60^\circ\text{C}$	P_{tot}	200	mW
Channel temperature	T_C	150	$^\circ\text{C}$
Storage temperature range	T_{stg}	-55 to +150	$^\circ\text{C}$

Maximum Thermal Resistance

Parameters	Symbol	Maximum	Unit
Channel ambient mounted on pc-board one side Cu 35 μm thickness (40 x 25 x 1.5) mm^3	R_{thCA}	450	K/W

Electrical DC Characteristics

$T_{amb} = 25^{\circ}\text{C}$, unless otherwise specified

Parameters / Test Conditions	Symbol	Min.	Typ.	Max.	Unit
Drain-source breakdown voltage $I_D = 10 \mu\text{A}$, $-V_{G1S} = -V_{G2S} = 4 \text{ V}$	$V_{(BR)DS}$	20			V
Gate 1-source breakdown voltage $\pm I_{G1S} = 10 \text{ mA}$, $V_{G2S} = V_{DS} = 0 \text{ V}$	$\pm V_{(BR)G1SS}$	6		20	V
Gate 2-source breakdown voltage $\pm I_{G2S} = 10 \text{ mA}$, $V_{G1S} = V_{DS} = 0 \text{ V}$	$\pm V_{(BR)G2SS}$	6		20	V
Gate 1-source cut-off current $\pm V_{G1S} = 5 \text{ V}$, $V_{G2S} = V_{DS} = 0 \text{ V}$	I_{G1SS}			50	nA
Gate 2-source cut-off current $\pm V_{G2S} = 5 \text{ V}$, $V_{G1S} = V_{DS} = 0 \text{ V}$	I_{G2SS}			50	nA
Drain current $V_{DS} = 15 \text{ V}$, $V_{G1S} = 0 \text{ V}$, $V_{G2S} = 4 \text{ V}$	I_{DSS}	2		20	mA
Gate 1-source cut-off voltage $V_{DS} = 15 \text{ V}$, $V_{G2S} = 4 \text{ V}$, $I_D = 20 \mu\text{A}$	$-V_{G1S(OFF)}$			2.5	V
Gate 2-source cut-off voltage $V_{DS} = 15 \text{ V}$, $V_{G1S} = 0 \text{ V}$, $I_D = 20 \mu\text{A}$	$-V_{G2S(OFF)}$			2.0	V

Electrical AC Characteristics

$V_{DS} = 15 \text{ V}$, $I_D = 10 \text{ mA}$, $V_{G2S} = 4 \text{ V}$, $f = 1 \text{ MHz}$, $T_{amb} = 25^{\circ}\text{C}$, unless otherwise specified

Parameters / Test Conditions	Symbol	Min.	Typ.	Max.	Unit
Forward transadmittance	$ y_{21} $	15	17		mS
Gate 1-input capacitance	C_{issg1}		2.2	2.6	pF
Gate 2-input capacitance $V_{G1S} = 0 \text{ V}$, $V_{G2S} = 4 \text{ V}$	C_{issg2}		1.1		pF
Feedback capacitance	C_{rss}		25	35	fF
Output capacitance	C_{oss}		0.8	1.2	pF
Power gain $V_{DS} = 15 \text{ V}$, $I_D = 10 \text{ mA}$, $V_{G2S} = 4 \text{ V}$, $g_G = 2 \text{ mS}$, $g_L = 0.5 \text{ mS}$, $f = 200 \text{ MHz}$ $g_G = 3.3 \text{ mS}$, $g_L = 1 \text{ mS}$, $f = 800 \text{ MHz}$	G_{ps} G_{ps}		25 18		dB dB
Noise figure $V_{DS} = 15 \text{ V}$, $I_D = 10 \text{ mA}$, $V_{G2S} = 4 \text{ V}$, $g_G = 2 \text{ mS}$, $f = 200 \text{ MHz}$ $f = 800 \text{ MHz}$	F F		1.0 1.8		dB dB

Dimensions in mm

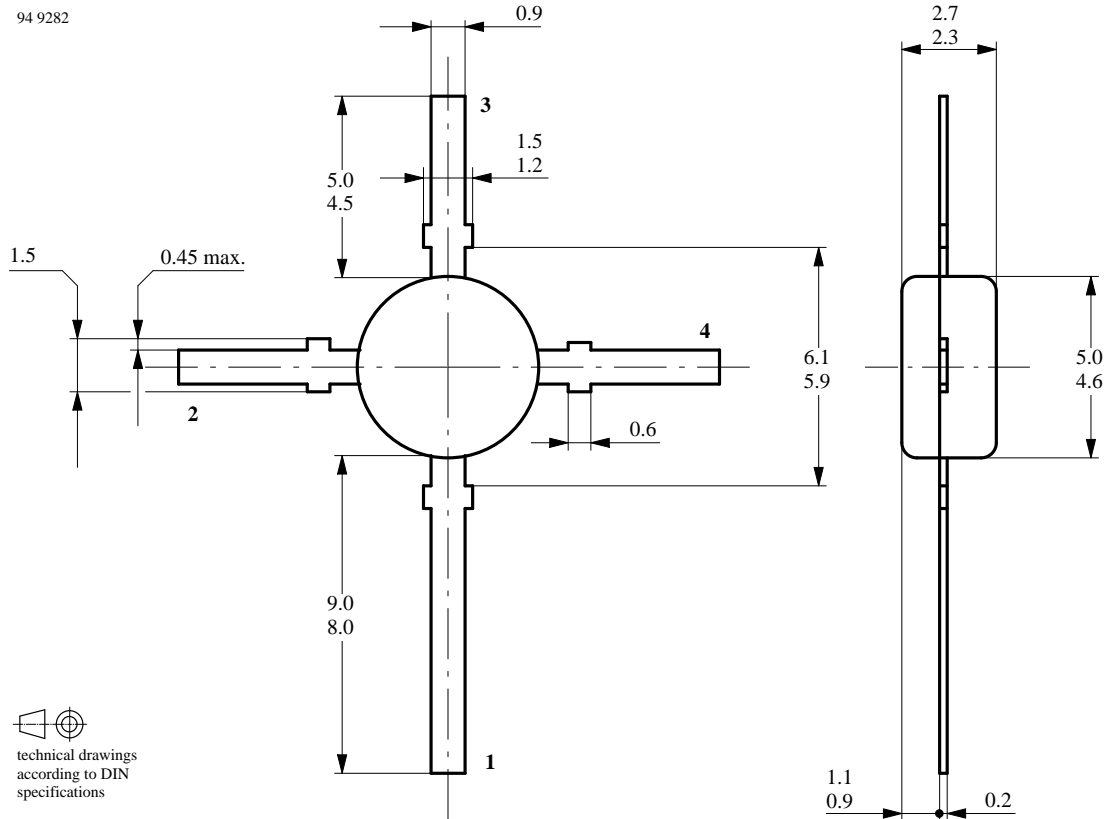

Ozone Depleting Substances Policy Statement

It is the policy of **TEMIC TELEFUNKEN microelectronic GmbH** to

1. Meet all present and future national and international statutory requirements.
2. Regularly and continuously improve the performance of our products, processes, distribution and operating systems with respect to their impact on the health and safety of our employees and the public, as well as their impact on the environment.

It is particular concern to control or eliminate releases of those substances into the atmosphere which are known as ozone depleting substances (ODSs).

The Montreal Protocol (1987) and its London Amendments (1990) intend to severely restrict the use of ODSs and forbid their use within the next ten years. Various national and international initiatives are pressing for an earlier ban on these substances.

TEMIC TELEFUNKEN microelectronic GmbH semiconductor division has been able to use its policy of continuous improvements to eliminate the use of ODSs listed in the following documents.

1. Annex A, B and list of transitional substances of the Montreal Protocol and the London Amendments respectively
2. Class I and II ozone depleting substances in the Clean Air Act Amendments of 1990 by the Environmental Protection Agency (EPA) in the USA
3. Council Decision 88/540/EEC and 91/690/EEC Annex A, B and C (transitional substances) respectively.

TEMIC can certify that our semiconductors are not manufactured with ozone depleting substances and do not contain such substances.

We reserve the right to make changes without further notice to improve technical design.

Parameters can vary in different applications. All operating parameters must be validated for each customer application by customer. Should Buyer use TEMIC products for any unintended or unauthorized application, Buyer shall indemnify TEMIC against all claims, costs, damages, and expenses, arising out of, directly or indirectly, any claim of personal damage, injury or death associated with such unintended or unauthorized use.

TEMIC TELEFUNKEN microelectronic GmbH, P.O.B. 3535, D-74025 Heilbronn, Germany
Telephone: 49 (0)7131 67 2831, Fax Number: 49 (0)7131 67 2423